

PK4840-PICK

48x40 (Standard) Plastic Picker Pallet



Technical Data

Dimensions	48x40x6.75 inches
Weight	44.0 lbs
Load Capacities	
Static	12000 lbs
Dynamic	3000 lbs
Racking	1800 lbs
Entry	4-way
Truckload Qty	390
Stack TL	13

TL (truckload) quantities are approximate and may vary by transport equipment or other factors.

Handling Data

Nestable No	Reusability Multi-Trip	ISPM-15 Exempt Yes
Stackable Yes	Destination Captive	Food Grade Yes, non-FDA
Rackable Yes	Airfreight No	Pharmaceutical Yes

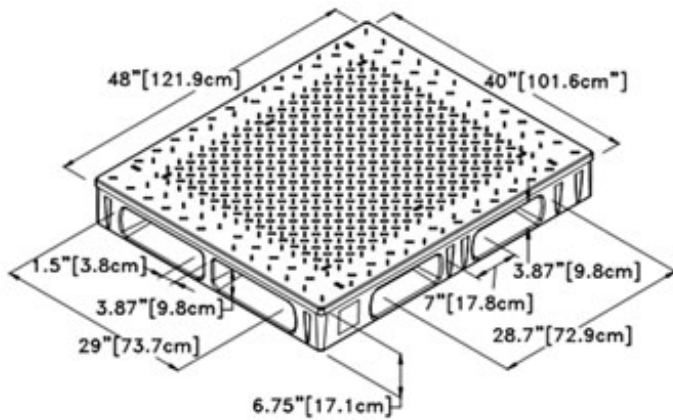

Materials and Colors

Condition New	
Material LLDPE	Color Black/Blue

(Linear Low Density Polyethylene)

Deck Specs

Top Deck
Closed

Bottom Deck
4 Runner - Perimeter+ Center Foot

Non-skid top

Features

- Compatible with middle grabber on most picker-style forklifts.
- Forklift safety straps all around
- Rackable with molded-in steel reinforcement
- Conveyorable
- Allows for safe double stacking
- Easy-to-clean hygienic design
- Suitable for packaged food items
(not approved for direct food contact)
- Impervious to acids, fats, solvents and odors
- Resists water absorption & bacteria growth
- Inert to infestation, mold and mildew
- Consistently dimensionally accurate
- Exempt from ISPM 15 shipping regulations

Nelson™

The Nelson Company
(443) 649-5294

plastic@NelsonCompany.com
www.NelsonCompany.com
www.NelsonTechCenter.com

Spec Sheet Generated On: 6/9/2023
Specs subject to change without notice. Provided for informational purposes only. Technical data are guideline values and may vary based on intended use, features, raw materials and environment. Nothing shall be construed as warranties or guarantees, express or implied, regarding products or their use, application, performance or otherwise.