

ST4840N-UniG2-22

48x40 (Standard) Plastic Industrial Pallet



Technical Data

Dimensions	48x40 inches (1219x1016 mm)
Weight	22.0 lbs
Load Capacities	
Static	7500 lbs
Dynamic	2600 lbs
Racking	--
Entry	4-way
Pallets per Stack	40
Truckload Qty	1200

Available in Truckload or LTL quantities. Minimum quantity required. We reserve the right to change any stated information without prior notice. Not responsible for typographical errors.

Materials and Colors

Condition
New

Material
HDPE (Recycled)
HDPE (Virgin*)

Color
Black
Gray/Custom*

*Custom colors and markings available in virgin material. (Minimum quantities required.)

Deck Specs

Top Deck

Closed
Anti-skid surfaces available

Bottom Deck

9 Feet - Nesting

Available Options:

Identification Stripes
Available in various weights depending upon load requirement

Handling Data

Nestable Yes	Reusability Multi-Trip	ISPM-15 Exempt Yes
Stackable No	Destination Captive	Food Grade Yes, non-FDA
Rackable No	Airfreight Yes	Pharmaceutical Yes

Features

- Shock-absorbing perimeter design virtually eliminates is splitting
- Beveled bottom edge allows for easy de-stacking
- 45 degree corner design
- Conveyable
- Nesting saves storage & shipping costs
- Easy-to-clean hygienic design
- Suitable for packaged food items (not approved for direct food contact)
- Impervious to acids, fats, solvents and odors
- Resists water absorption & bacteria growth
- Inert to infestation, mold and mildew
- Consistently dimensionally accurate
- Exempt from ISPM 15 shipping regulations

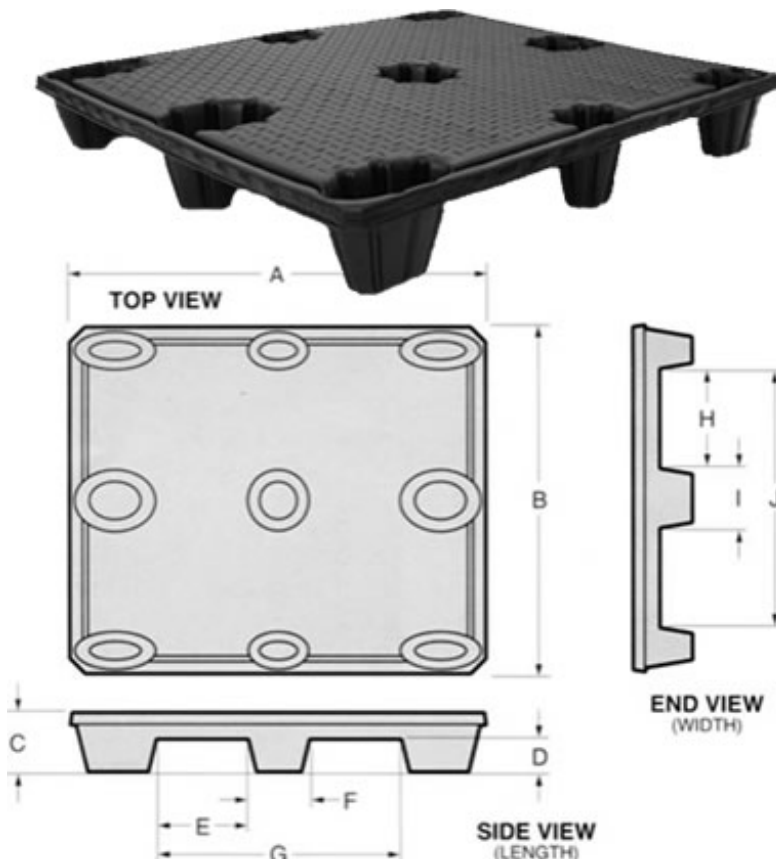

NelsonTM

The Nelson Company

(410) 477-3000 x110

plastic@NelsonCompany.com

www.NelsonCompany.com

www.NelsonTechCenter.com