

NPP-4840-N-RN21Ibs

48x40 (Standard) Plastic Industrial Pallet



Technical Data

Dimensions 48x40x5 inches (1219x1016x127 mm)
Weight 21.0 lbs

Load Capacities

Static 6000 lbs
Dynamic 3000 lbs
Racking 2200 lbs

Entry 4-way
Pallets per Stack 47
Truckload Qty 1410

Available in Truckload or LTL quantities. Minimum quantity required. We reserve the right to change any stated information without prior notice. Not responsible for typographical errors.

Handling Data

Nestable Yes
Reusability One-Way & Multi-Trip
ISPM-15 Exempt Yes

Stackable Yes
Destination Captive & Export
Food Grade Yes, non-FDA

Rackable Yes
Airfreight Yes
Pharmaceutical Yes



Materials and Colors

Condition
New

Material HDPP (Recycled) **Color** Black

(High-Density Polypropylene)

Deck Specs

Top Deck
Open

Bottom Deck
4 Runner - Unidirectional Long Side

Racking only on the 48 inch side
Optional anti-slip feet available

Features

Revolutionary Rackable & Nestable Design closely resembles wood pallet. Engineered to look and function like a traditional, wooden stringer pallet.

- Low profile (5") great for airfreight
- Automation friendly
- Compatible with most roller conveyors
- Nesting saves storage & shipping costs
- Allows for safe double stacking
- Easy-to-clean hygienic design
- Suitable for packaged food items
(not approved for direct food contact)
- Impervious to acids, fats, solvents and odors
- Resists water absorption & bacteria growth
- Inert to infestation, mold and mildew
- Consistently dimensionally accurate
- Exempt from ISPM 15 shipping regulations

Nelson™

The Nelson Company

(410) 477-3000 x110

plastic@NelsonCompany.com

www.NelsonCompany.com

www.NelsonTechCenter.com

NPP-4840-N-RN21Ibs

48x40 (Standard)
Plastic Industrial Pallet



Technical Drawings

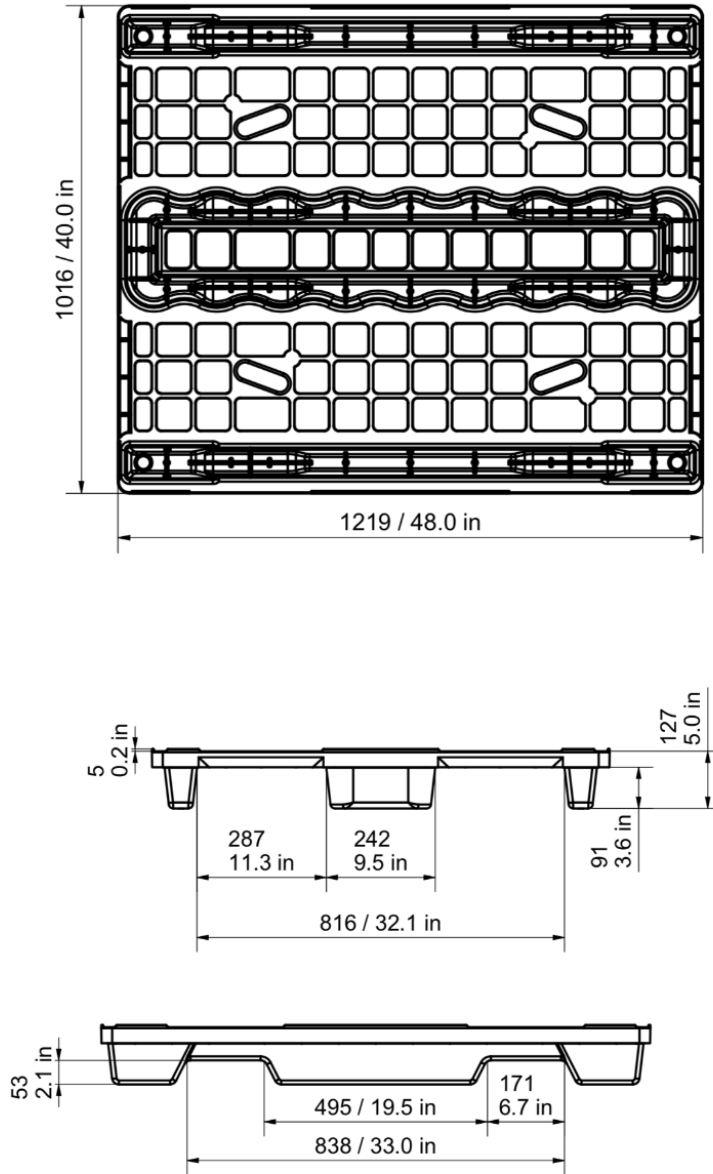

NelsonTM

The Nelson Company
(410) 477-3000 x110

plastic@NelsonCompany.com

www.NelsonCompany.com

www.NelsonTechCenter.com